

iMAT-1118
Antenna element

iMAT-1118-A
Assembly including antenna element, PCB,
and connectors as shown

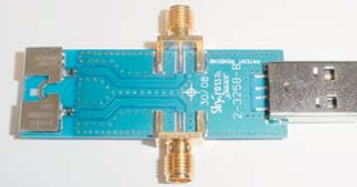

iMAT
2.7-2.9 GHz
WiMAX Antenna

Features

- Single antenna structure with multiple feeds behaves like multiple antennas
- Ready-made diversity or MIMO antenna system
- High isolation, low correlation, and high efficiency in a very small footprint
- Surface mount technology & common materials translate to cost effective manufacturing

Mechanical Specifications

Antenna Element	0.32 x 0.71 x 0.09 in
	8.2 x 18 x 2.2 mm
Assembly PCB	2.12 x 0.75 in
	54.0 x 19.0 mm
Area of PCB that is Ground	1.7 x 0.75 in
	43.0 x 19.0 mm
Antenna Element Weight	0.4 g

Electrical Specifications

Frequency Range	2.7-2.9 GHz
Gain	>1.2 dBi at 2.8 GHz
VSWR	<2.5:1 across band
Isolation	< -8 dB across band
Envelope Correlation Coefficient	<0.3 across band
Polarization	Linear
Radiation Pattern	Elevation onmi-directional
Feed Impedance	50 Ohms Unbalanced

All antenna measurements are taken in free space. Antenna will need to be customized (tuned and/or trimmed) to achieve similar performance when fitted in a plastic enclosure. Results may vary depending on the particular implementation.

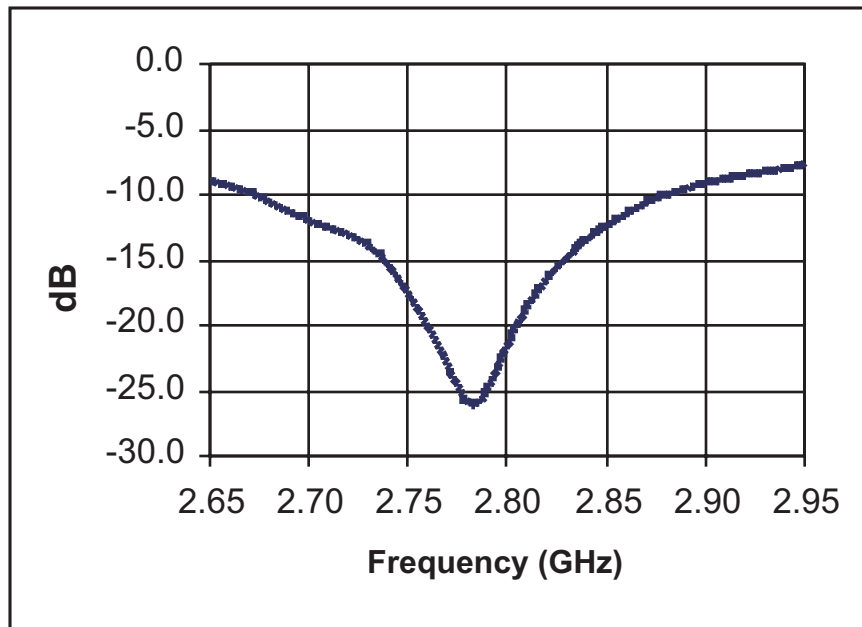
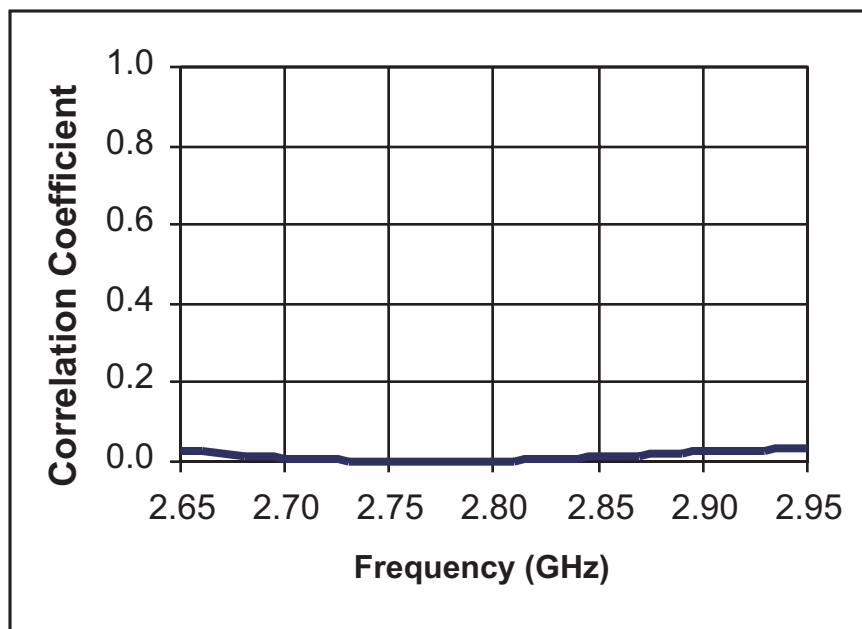
Isolation: S21 (1 to 2)**Envelope Correlation Coefficient**

Port 1

Port 2

VSWR

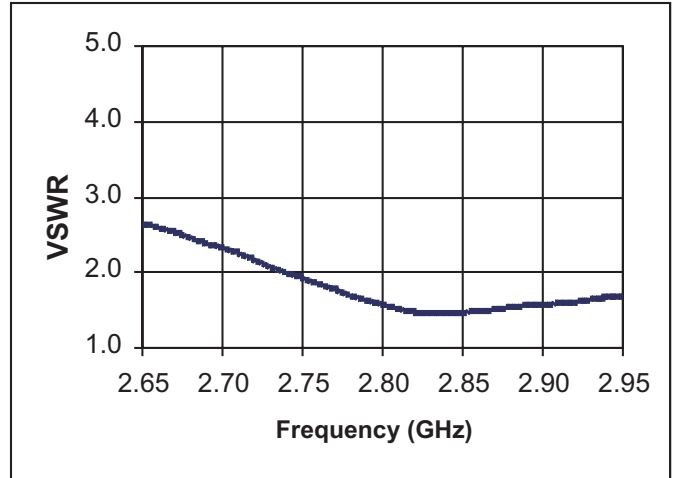
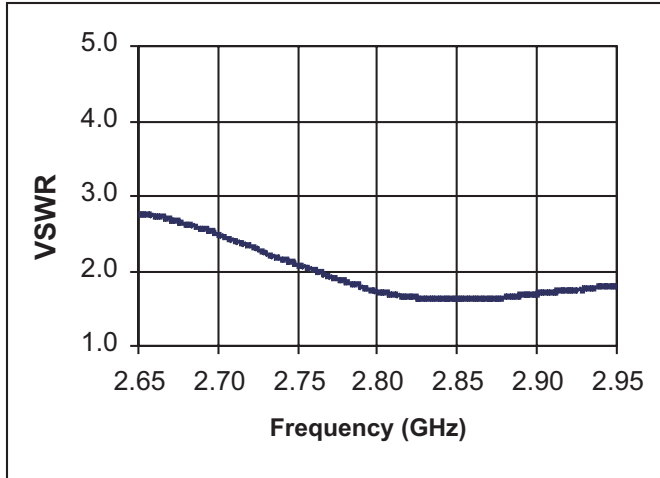

Peak Gain

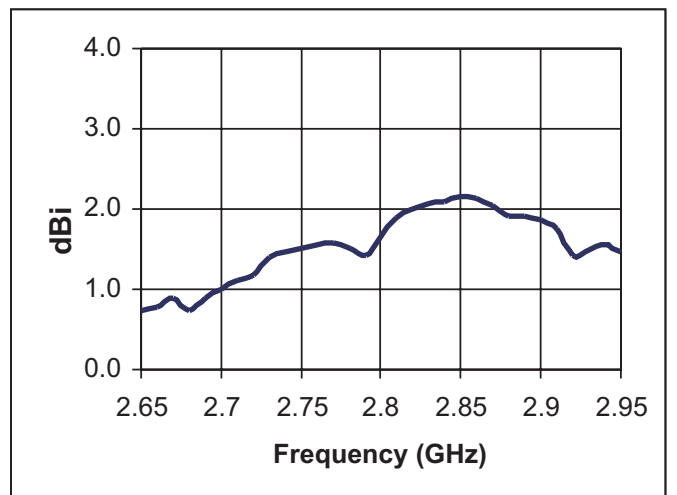
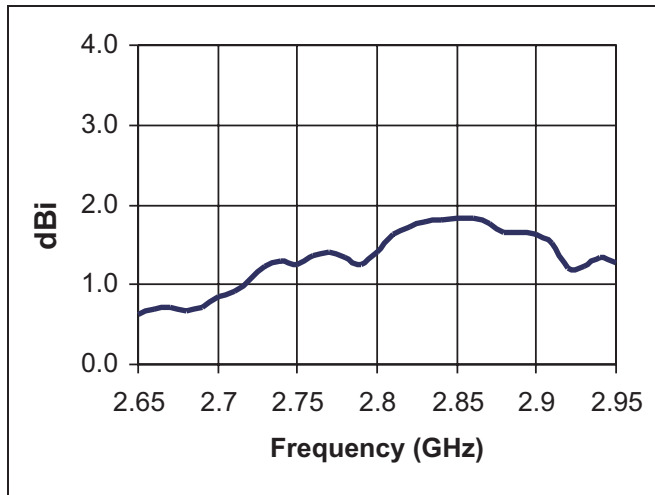

Efficiency

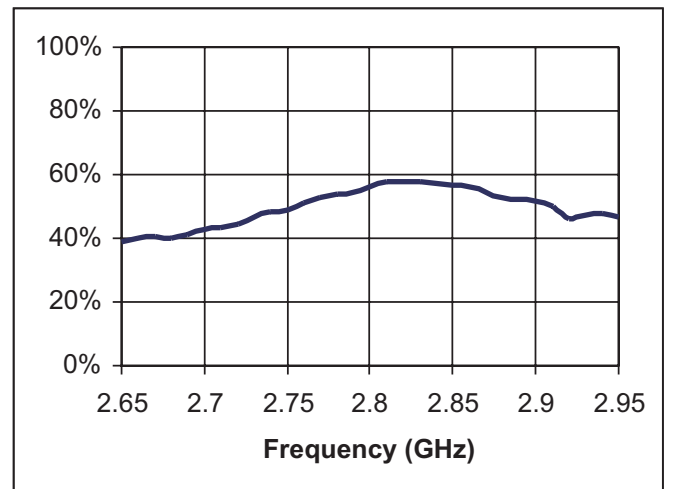
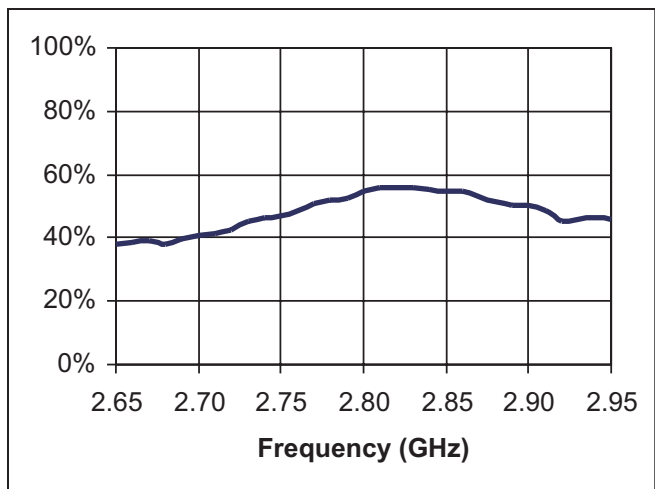

Diagrams Below are at 2.8 GHz

Port 1

Port 2

Elevation Cut **Phi=0 Degrees**

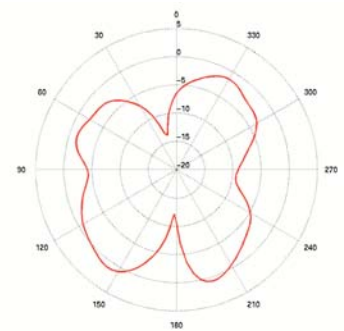
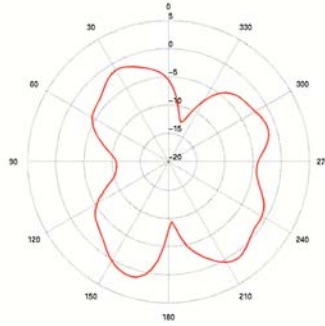

Elevation Cut **Phi=90 Degrees**

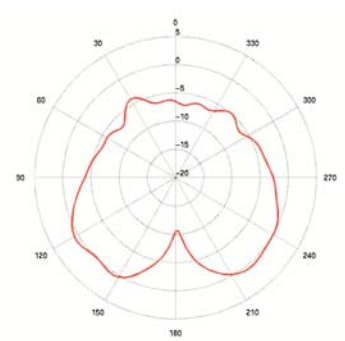
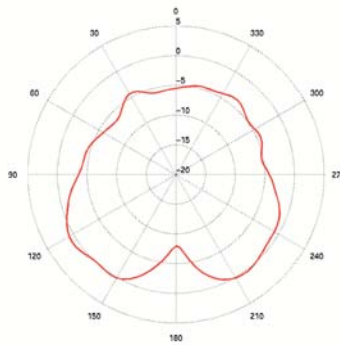

Azimuth Cut **Theta=90 Degrees**

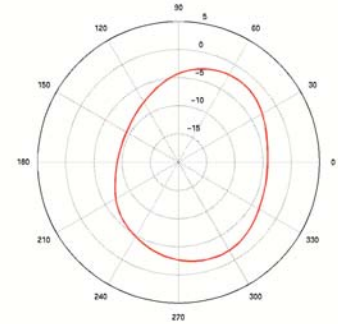
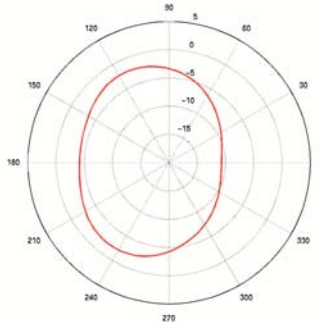

Spherical Gain Contour Map

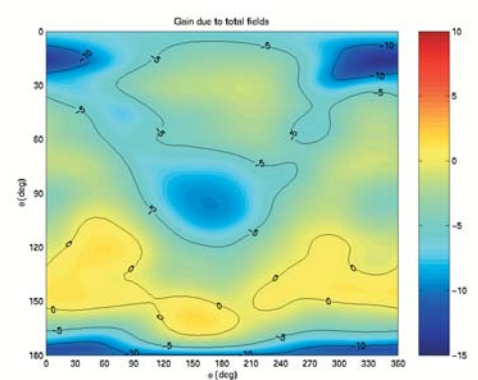
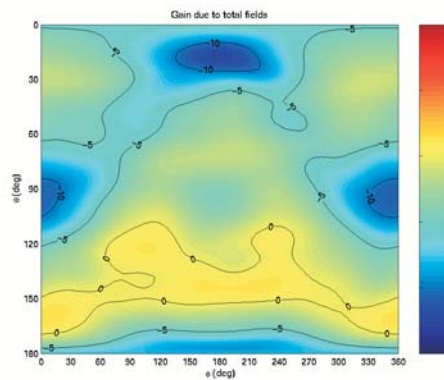
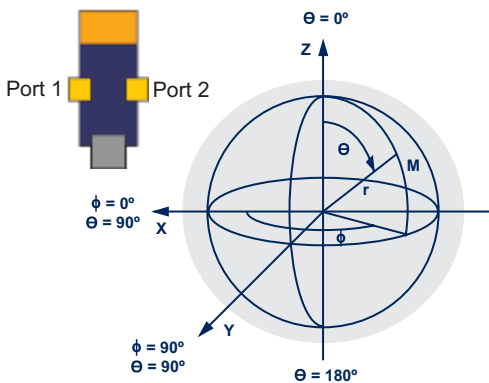

Footprint

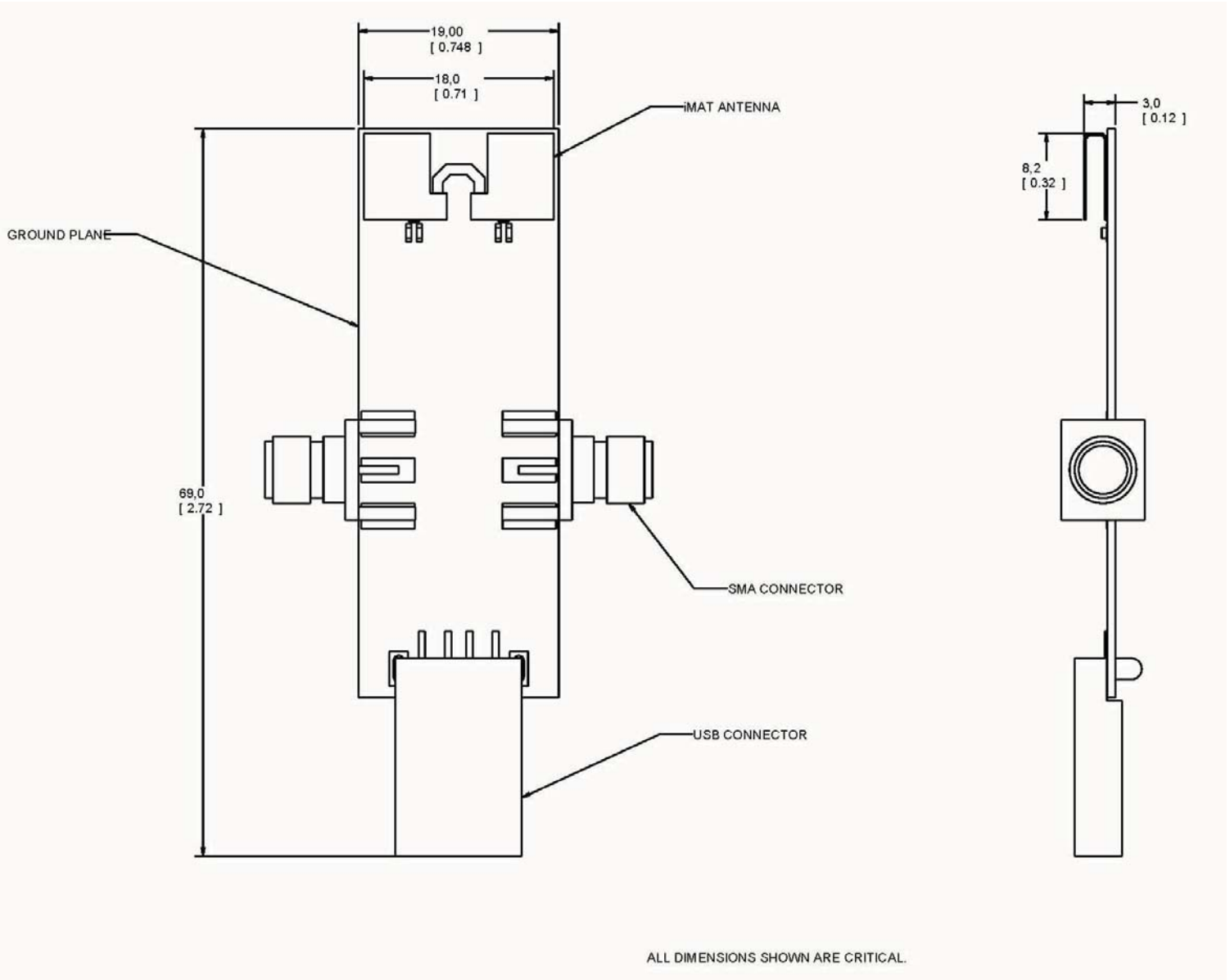

Footprint

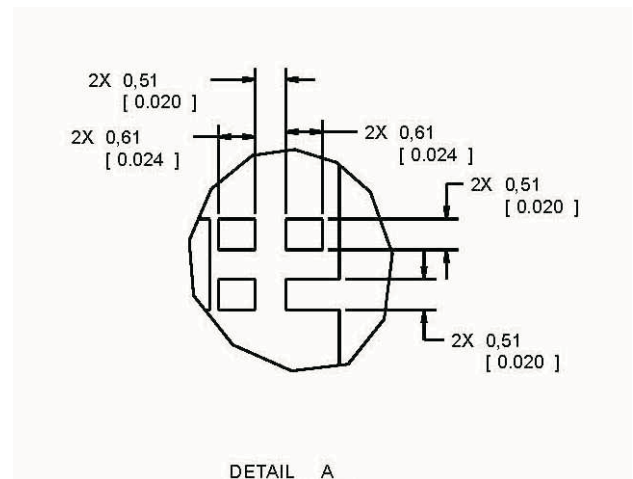
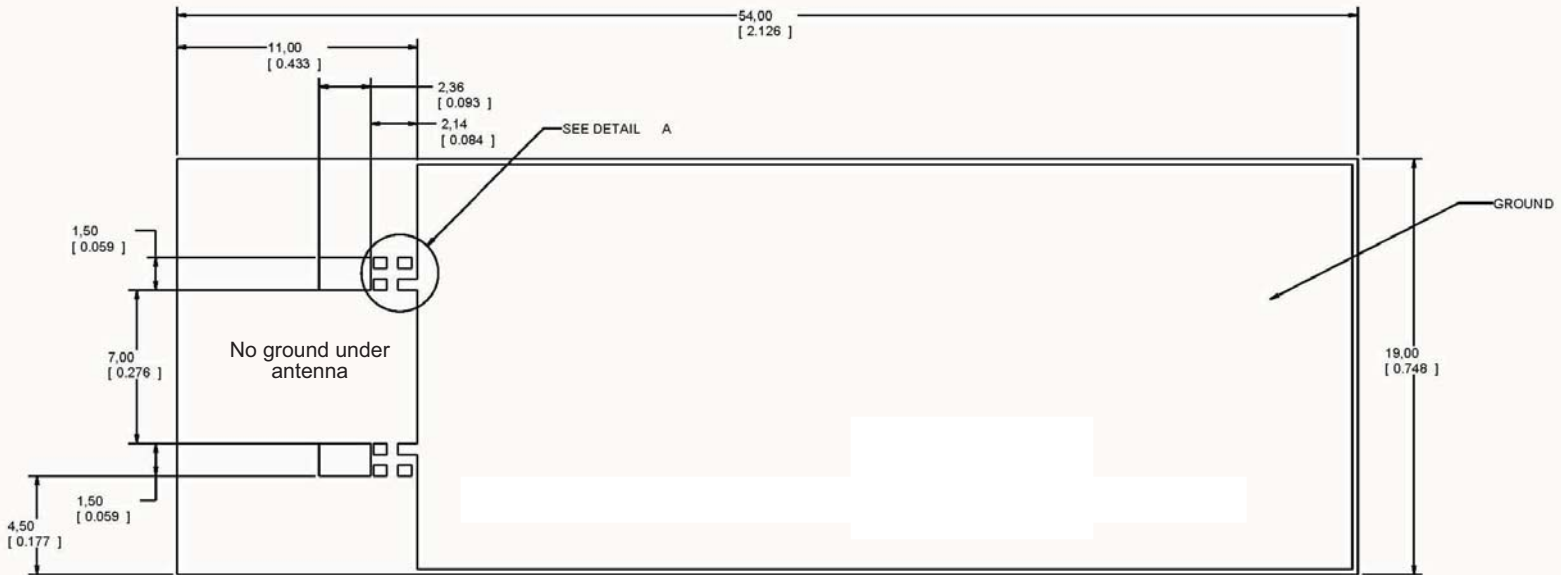

www.skycross.com

SkyCross has many offices worldwide.
Visit us online to find an office near you.